

RECOMMENDED  
MOUNTING HOLE

RevNo	Revision note	Date	Checked
1	Initial Release	11214	GC
2	Overall Length changed to 245mm	11214	GC
3	10.55" part added	120814	GC
4	Shrinktubing added; Sensity Pt. #'s changed	04.0215	GC

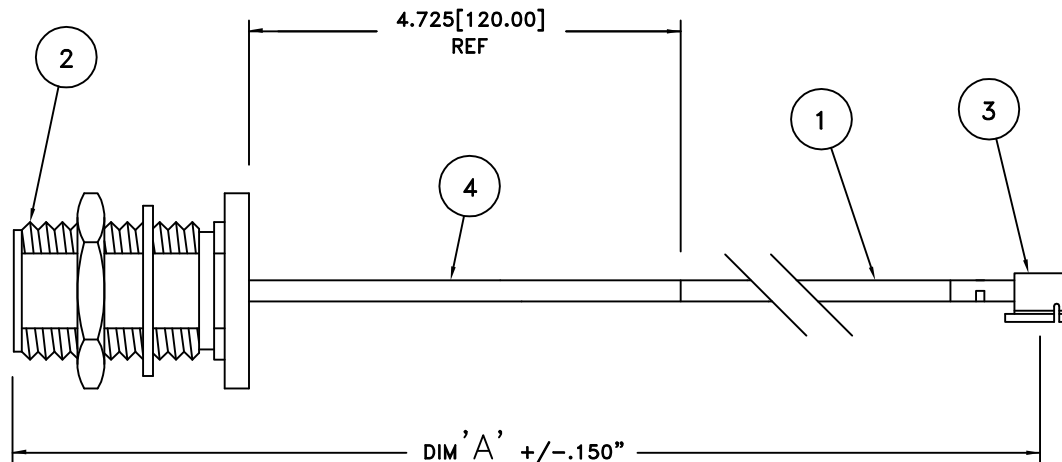

NOTES:

1. STRIP CABLE ENDS IN ACCORDANCE WITH CONNECTOR SPEC SHEETS.
2. CONSTRUCT CABLE ASSEMBLY IN ACCORDANCE WITH PROCEDURES.
3. TAG WITH PART NUMBER, QUANTITY, AND CUSTOMER PART NUMBER.
4. NOTE CONNECTOR ALIGNMENTS
5. MUST USE RoHS COMPLIANT MATERIALS

PART NO.	DIM "A"		SENSITY PART NUMBER
	INCHES	MILLIMETERS	
MWAS-2120-8.27	8.27	210.00	400-0310-00
MWAS-2120-9.65	9.65	245.00	
MWAS-2120-10.55	10.55	268.00	400-0309-00

MATERIALS

- 1 COAXIAL CABLE, 1.32mm DS GRAY
- 2 MW-350-132DS, N BULKHEAD JACK for 1.32mm DS
- 3 U.FL PLUG, HIROSE U.FL-LP-066 for 1.32 Cable
- 4 SHRINKTUBE, BLACK 1/16" POLYOLEFIN

MILLIMETER WAVE TECHNOLOGIES  
6501 W. FRYE ROAD, #23  
CHANDLER, AZ 85226

CABLE ASSEMBLY  
N BULKHEAD JACK - U.FL PLUG  
1.32mm DS

Designed by G.COLEMERE	Checked by W. CANON	Approved by N. JAIN	File name MWAS-2120	TITLE MWAS-2120
---------------------------	------------------------	------------------------	------------------------	--------------------

TOLERANCES  
DIMENSIONS ARE IN INCHES UNLESS  
OTHERWISE SPECIFIED  
DECIMALS ANGULAR  
.XX ± .02 ± .06  
.XXX ± .005  
DO NOT SCALE THIS DRAWING

ALL DIMENSIONS ON THIS DRAWING ARE FOR REFERENCE  
PURPOSES ONLY AND ARE SUBJECT TO CHANGE

REV. 4	Scale NONE
DATE 11214	Sheet 1 of 1