

RevNo	Revision Notes	Date	Checked
1	RoHS Compliant	052605	PC

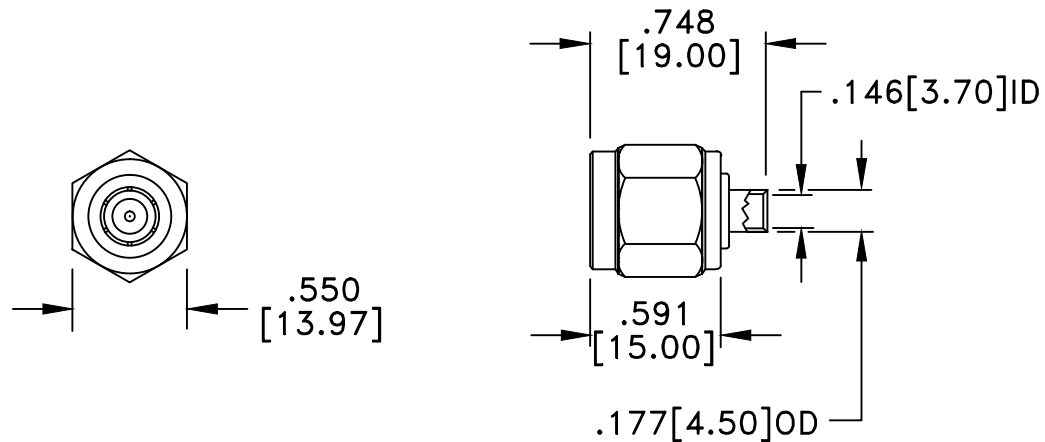
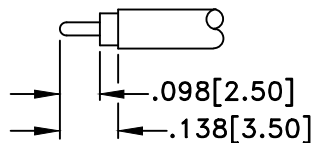

RoHS Compliant

MATERIALS

BODY	BRASS
BODY PLATING	NICKEL
CONTACT	BRASS
CONTACT PLATING	GOLD
SHANK	BRASS
SHANK PLATING	GOLD
DIELECTRIC	TEFLON (PTFE)

50 Ohm IMPEDANCE
500V PEAK VOLTAGE RATING
TEMPERATURE RANGE: -55°C TO +155°C
INTERFACE DIMENSIONS SIMILAR TO MIL-C-39012

MILLIMETER WAVE TECHNOLOGIES
6501 W. FRYE ROAD, #23
CHANDLER, AZ 85226

TNC MALE SOLDER CABLE END
for .141" SEMI-RIGID
BUILT-IN CONTACT

Designed by G.COLEMERE	Checked by S. NEUGESS	Approved by A. LEE	File name MW-750H-141	TITLE MW-750H-141
TOLERANCES DIMENSIONS IN INCHES UNLESS OTHERWISE SPECIFIED DECIMALS ANGULAR .XX ± .02 ± .06 .XXX ± .005				ALL DIMENSIONS ON THIS DRAWING ARE FOR REFERENCE PURPOSES ONLY AND ARE SUBJECT TO CHANGE.
				REV. 1 DATE 031202 Scale NONE Sheet 1 of 1