

RevNo	Revision Notes	Date	Checked
1	Dielectric Material Clarified	071801	G.C.
2	RoHS Compliant	022205	PC

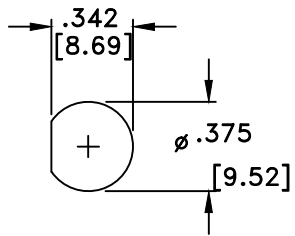

RECOMMENDED MOUNTING HOLE

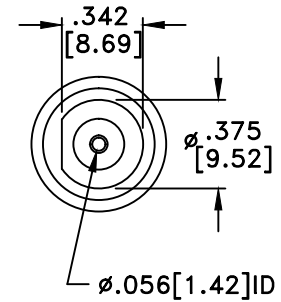
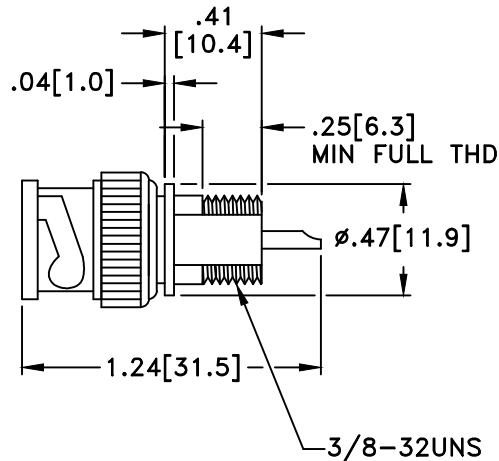
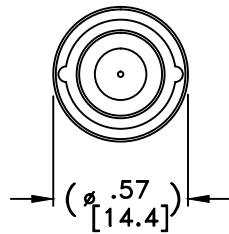

RoHS Compliant

MATERIAL	
BODY	BRASS
BODY PLATING	NICKEL
CONTACT	BRASS
CONTACT PLATING	GOLD
DIELECTRIC	TEFLON (PTFE)
HEX NUT	BRASS
HEX NUT PLATING	NICKEL
LOCK WASHER	SPRING STEEL
WASHER PLATING	NICKEL
SOLDER LUG	STEEL
LUG PLATING	NICKEL

75 Ohm IMPEDANCE
500V PEAK VOLTAGE RATING
TEMPERATURE RANGE: -55°C TO +155°C
INTERFACE DIMENSIONS SIMILAR TO MIL-C-39012

INCLUDES HEX NUT, INTERNAL TOOTH LOCKWASHER AND SOLDER LUG

MILLIMETER WAVE TECHNOLOGIES 6501 W. FRYE ROAD, #23 CHANDLER, AZ 85226			BNC MALE BULKHEAD FRONT MOUNT 75 OHMS			
Designed by N. JAIN	Checked by W. CANON	Approved by A. LEE	File name MW-215-75D	TITLE MW-215-75D		
TOLERANCES DIMENSIONS ARE IN INCHES UNLESS OTHERWISE SPECIFIED DECIMALS ANGULAR .XX ± .02 ± .06 .XXX ± .005 DO NOT SCALE THIS DRAWING			ALL DIMENSIONS ON THIS DRAWING ARE FOR REFERENCE PURPOSES ONLY AND ARE SUBJECT TO CHANGE.		REV. 2 DATE 021001	Scale NONE Sheet 1 of 1