

RevNo	Revision Notes	Date	Checked
1	RoHS Compliant	100205	PC

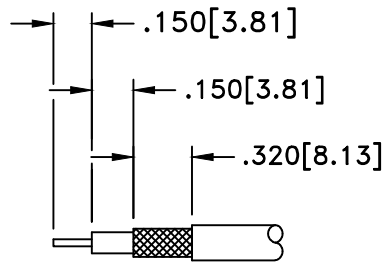

STRIP LENGTHS
M17/93-RG178

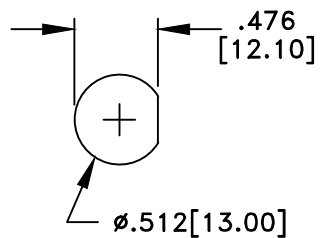

RECOMMENDED
MOUNTING HOLE

RoHS Compliant

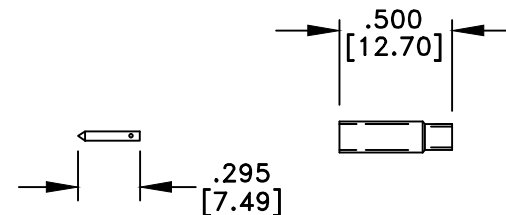
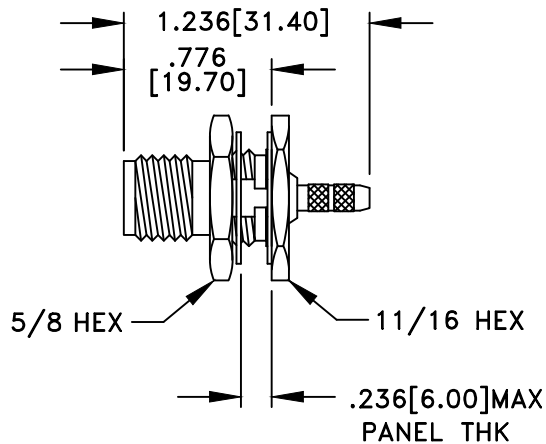

MATERIALS

BODY	BRASS
BODY PLATING	NICKEL
CONTACT	PHOSPHOR BRONZE
CONTACT PLATING	GOLD
DIELECTRIC	TEFLON (PTFE)
O-RING GASKET	SILICONE RUBBER

50 Ohm IMPEDANCE
500V PEAK VOLTAGE RATING
TEMPERATURE RANGE: -55°C TO +155°C
INTERFACE DIMENSIONS SIMILAR TO MIL-C-39012

MILLIMETER WAVE TECHNOLOGIES
6501 W. FRYE ROAD, #23
CHANDLER, AZ 85226

TNC JACK BULKHEAD
CRIMP CABLE END
for RG178

Designed by
P. CHEN

Checked by
S. NEUGESS

Approved by
A. LEE

File name
MW-780-E-178

TITLE
MW-780-E-178

TOLERANCES
DIMENSIONS IN INCHES UNLESS OTHERWISE SPECIFIED
DECIMALS ANGULAR
.XX ± .02 ± .06
.XXX ± .005

ALL DIMENSIONS ON THIS DRAWING ARE FOR REFERENCE
PURPOSES ONLY AND ARE SUBJECT TO CHANGE.

REV. 1	Scale NONE
DATE 072601	Sheet 1 of 1