

RevNo	Revision Notes	Date	Checked
1	RoHS Compliant	100213	PC
2	Pin design added	121317	PC
3	Rear thread corrected to read 5/8-24 UNEF	032919	GC

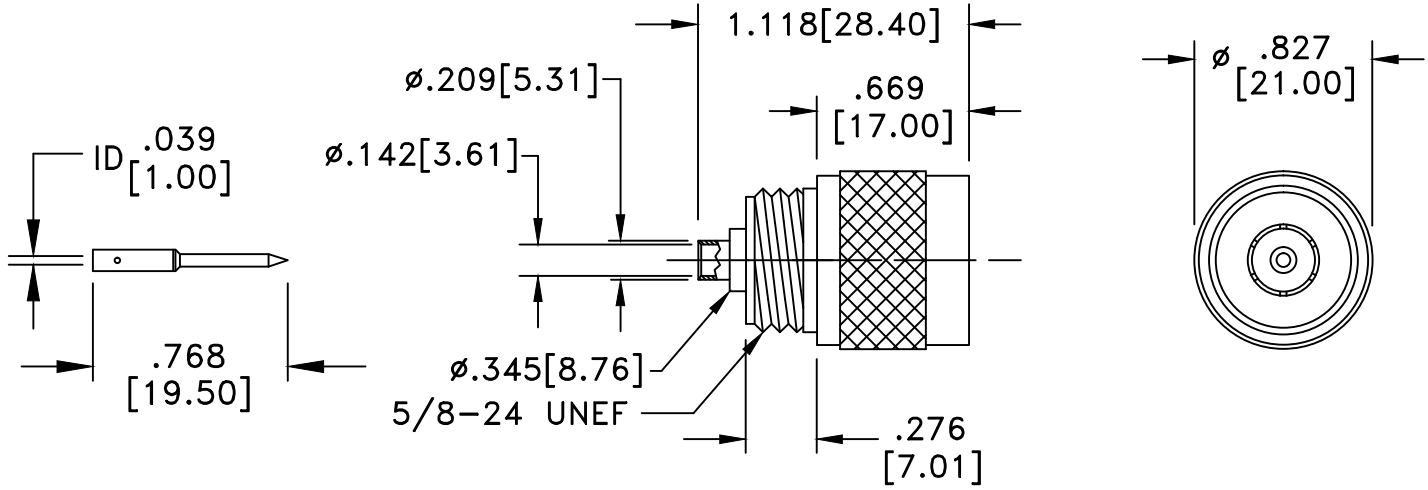
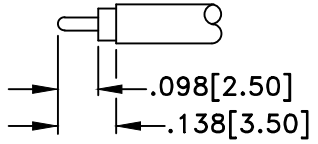

RoHS Compliant

MATERIALS	
BODY	BRASS
BODY PLATING	BLACK CHROME
CONTACT	BRASS
CONTACT PLATING	GOLD
DIELECTRIC	TEFLON (PTFE)
SHANK PLATING	GOLD
50 Ohm IMPEDANCE 500V PEAK VOLTAGE RATING TEMPERATURE RANGE: -55°C TO +155°C INTERFACE DIMENSIONS SIMILAR TO MIL-C-39012	

MILLIMETER WAVE TECHNOLOGIES 6501 W. FRYE ROAD, #23 CHANDLER, AZ 85226			N MALE THREADED SOLDER CABLE END for .141" S/R			
Designed by P. CHEN	Checked by S. NEUGESS	Approved by A. LEE	File name MW-353-BC-141	TITLE MW-353-BC-141		
TOLERANCES DIMENSIONS IN INCHES UNLESS OTHERWISE SPECIFIED DECIMALS .XX ± .02 .XXX ± .005			ALL DIMENSIONS ON THIS DRAWING ARE FOR REFERENCE PURPOSES ONLY AND ARE SUBJECT TO CHANGE.		REV. 3 DATE 100213	Scale NONE Sheet 1 of 1